

COOL FLAME

PD PRO 1500

Water Vapour Cassette with Lumisty Technology



LUMISTY TECHNOLOGY

Lumisty Technology is a proprietary system that creates a flame-like visual effect using a silent ultrasonic mist generator enhanced with heater and fans combined with active LED lighting.



SIMPLIFIED INSTALLATION

Drop-in installation - the cassette is dropped into an opening and supported by the trim rather than legs. No venting slots required underneath.

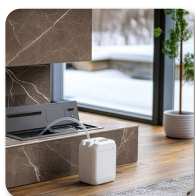

FLEXIBLE REFILLING

Three water supply options: integrated refill pump, external water tank connection, or direct water network connection for fully automatic operation.



AROMA MODULE

The integrated aroma system can be activated on demand and offers programmable release intervals and adjustable intensity settings for your preferred scent dispersion.



REMOTE CONTROL

The multifunctional remote allows for direct adjustment of flame tones, colour gradients, and flame height. You can also activate the crackling-wood sound for a multi-sensory experience.



LCD TOUCH SCREEN

The integrated touch screen allows for direct system status viewing and settings adjustments. A digital slider offers precise control over flame tones, color gradients, and flame height as well as additional crackling effect.

All product specifications and data are subject to change without notice and are believed to be accurate as of the date hereof. Planika Sp. z o.o., its affiliates, agents, and employees, and all persons acting on its or their behalf (collectively, "Planika Sp. z o.o."), disclaim any and all liability for any errors, inaccuracies or incompleteness contained in any document or in any other disclosure relating to any product. To the maximum extent permitted by applicable law, Planika Sp. z o.o. disclaims any and all liability arising out of the application or use of any product. No license, express or implied, by estoppel or otherwise, to any intellectual property rights is granted by this document or by any conduct of Planika Sp. z o.o.. Customers using or selling Planika Sp. z o.o.'s products not expressly indicated for use in such applications do so entirely at their own risk and agree to fully indemnify Planika Sp. z o.o. for any damages arising or resulting from such use or sale. The provided fuel consumption is based on laboratory testing on the lowest flame level. The actual consumption of individual devices may vary. The images are indicative only.

COOL FLAME

PD Pro 1500

Tank capacity	2.7 L 0.7 gal
Maximum operation time	18 hours / unlimited with the direct water net supply connection
Heating function	does not apply
Flame height	smooth regulation
Weight	35 kg 77 lb
Water type	filtered tap water / distilled water
Flue	not required
Power supply	230 V 115 V, 50 Hz
Refilling method	integrated refill pump external water tank connection direct water net supply connection
Finish	black powder coating
Materials	steel
Application	for indoor use only

CONTROL OPTIONS



remote control

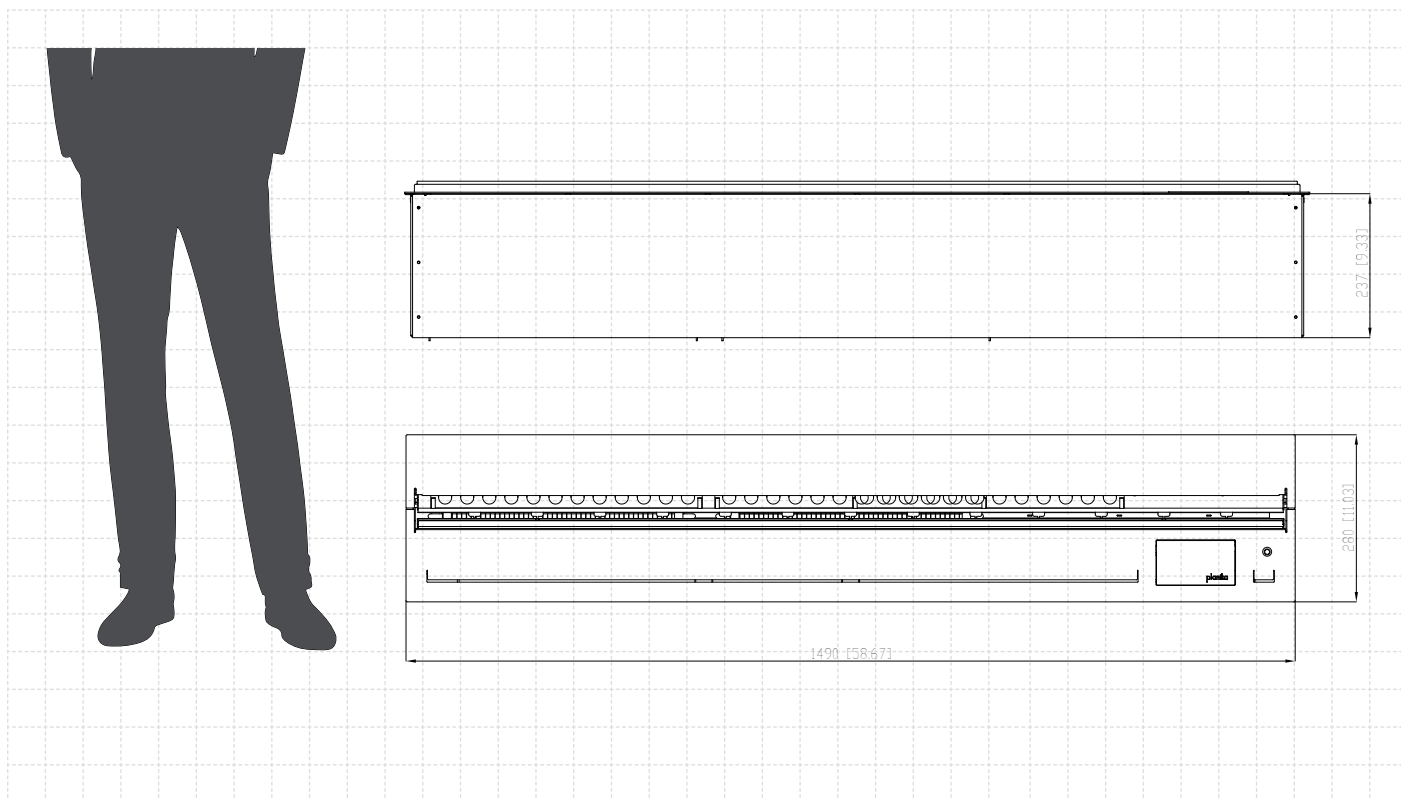

All product specifications and data are subject to change without notice and are believed to be accurate as of the date hereof. Planika Sp. z o.o., its affiliates, agents, and employees, and all persons acting on its or their behalf (collectively, "Planika Sp. z o.o."), disclaim any and all liability for any errors, inaccuracies or incompleteness contained in any document or in any other disclosure relating to any product. To the maximum extent permitted by applicable law, Planika Sp. z o.o. disclaims any and all liability arising out of the application or use of any product. No license, express or implied, by estoppel or otherwise, to any intellectual property rights is granted by this document or by any conduct of Planika Sp. z o.o.. Customers using or selling Planika Sp. z o.o.'s products not expressly indicated for use in such applications do so entirely at their own risk and agree to fully indemnify Planika Sp. z o.o. for any damages arising or resulting from such use or sale. The provided fuel consumption is based on laboratory testing on the lowest flame level. The actual consumption of individual devices may vary. The images are indicative only.